

THESIS PROPOSAL



Virginia Advanced Shipbuilding & Carrier Integration Center Newport News, VA

John Boyle
Structural Option
Advisor: Dr. Richard Behr
October 4, 2010

TABLE OF CONTENTS

Executive Summary.....	3
Introduction.....	4
Structural Systems Overview.....	5
Foundation.....	5
Floor System.....	8
Roof System.....	10
Columns.....	11
Lateral System.....	12
Structural Details.....	15
Conclusions.....	17
Problem Statements.....	18
Problem Solution.....	18
Breadth Study I.....	19
Breadth study II.....	19
Proposed Solutions & Methods.....	19
Tasks.....	20
Schedule.....	21

Executive Summary

The Virginia Advanced Shipbuilding & Carrier Integration Center is an office building located in Newport News, Virginia. Research as well as business takes place in this impressive glass-encased building. The building is shaped like a tall, glass ship that looms over the James River giving the building deep symbolism as well as architectural appeal. The office looks to achieve a light, open feel and makes use of a steel structure to do so.

The building's shape creates problems within the building. First, column spacing is irregular. Irregular column spacing leads to irregular beam and joist placement. The irregular bays created by column spacing and beam placement lead to great differences in floor thickness throughout the building. In Technical Report II three alternative floor systems were analyzed. It was observed that a two-way flat concrete slab as well as a concrete column system would reduce the floor thickness. The use of a flat slab would allow the building to use a uniform floor thickness as well as eliminate the problems caused by irregular beam and joist placement.

The first drawback to using a concrete slab to resist gravity loads is the need for a redesign for the lateral load resisting system. The existing system is a steel "K" braced frame that coincides with the wide flange beams used in the existing gravity resisting system. The new design would have to make use of shear walls.

Another drawback to using concrete is the risk that the building may suffer architecturally. As previously stated, the building looks to achieve an open, light feel. Steel is the optimal material to achieve this idea. The concrete redesign would have to achieve a smaller floor thickness in an attempt to sustain or improve the floor-to-ceiling heights. The column layout must also be redesigned. Columns should be well-spaced to keep an open feel. Smaller column sizes will be used to keep the light feel the steel columns were able to achieve.

Several different column layouts will be analyzed in order to find the layout most suitable for the building. Concrete costs will be taken into account as well as the impact concrete construction will have on the construction schedule. Finally, the end result will be compared to the existing steel structure to determine which system is most feasible for the Virginia Advanced Shipbuilding & Carrier Integration Center.

Introduction

The Virginia Advanced Shipbuilding and Carrier Integration Center was designed by Clark Nexsen. The project consists of two main buildings: the office building and the lab wing complete with lab parking and a parking deck. The office building is a typical composite steel frame design. The steel frame grid consists of wide flange beams and columns that range from W12x14 to W18x40. The Lab wing consists of concrete slab with concrete columns and precast concrete walls.

The office building is elevated on “stilts” of concrete made of concrete piles surrounding wide flange steel columns.



Source: Clark Nexsen

The first floor consists of a 5” reinforced concrete slab in the main office area, an 8” reinforced concrete slab at the front of the building and a 6” reinforced concrete slab in the stairwells. The rest of the floors consist of a grid of wide flange steel columns and beams that is shaped into the unique curved design of the Virginia Advanced Shipbuilding and Carrier Integration Center. The composite steel deck and slab is 4.5” in total thickness and consists of lightweight concrete placed on a 2” deep, .038” thick galvanized steel deck.

The lab wing consists of 24”x24” precast concrete columns, 8” precast lightweight concrete walls, and 4” reinforced concrete slabs. The roof of the lab wing consists of gable trusses with steel deck.

Structural Systems Overview

1. Foundation

A. Office Building

The foundation of the office building consists of a wide-flange steel column on a concrete pedestal. These concrete pedestal/steel column arrangements are placed around the perimeter of the office building in a shape that resembles a football. The soil condition on the site consists of unstable soil due to the waterfront location of the building. This shape is repeated for interior columns as well. *Figure 1* shows the plan view of the concrete pedestal/steel column arrangement and *Figure 2* shows the section view.

FIGURE 1 - Source: Clark Nexsen

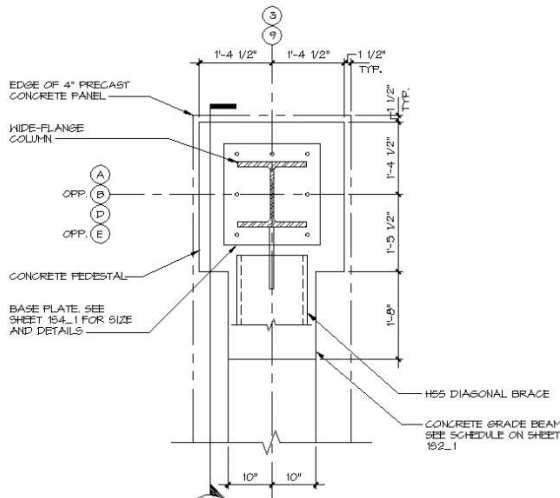
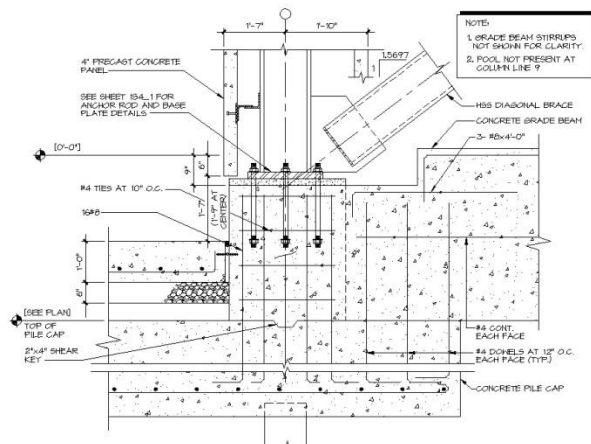

FIGURE 2 – Source: Clark Nexsen



The concrete used in these arrangements is 3000 psi concrete. It is reinforced by #4 ties at 10”O.C, a 2”x4” shear key, and 16 #8 steel rebar. These concrete piles support the wide flange columns that are placed on them and connected with steel plates and anchor rods.

Two grade beams are used in the foundation of the office building. These grade beams are used to resist lateral column base movement as well as distribute the weight of the building over the soil. These grade beams are important due to the unstable soil condition on the site. Lateral column base movement is important in this project as it is on the coast of the James River. A bulkhead of steel sheet pile had to be constructed to resist the water pressure of the river as well as to provide slope stability and increase bearing capacity for the building foundation. They also serve to increase the bearing capacity for the building foundation. The grade beams are used to further this insurance

that the building will not be affected by the river. *Table 1* shows the width, depth and reinforcing of these grade bars.

TABLE 1 – Source: Clark Nexsen

GRADE BEAM SCHEDULE						
MARK	WIDTH	DEPTH	TOP BARS	BOTTOM BARS	STIRRUPS	
					SIZE	SPACING
GB1	22"	46"	4 - #8	4 - #8	#4	12" O.C.
GB2	20"	50"	4 - #7	4 - #7	#4	12" O.C.

Figure 3 shows the locations of the grade beams. GB1 is indicated in blue and GB 3 is indicated in red.

FIGURE 3 – Source: Clark Nexsen

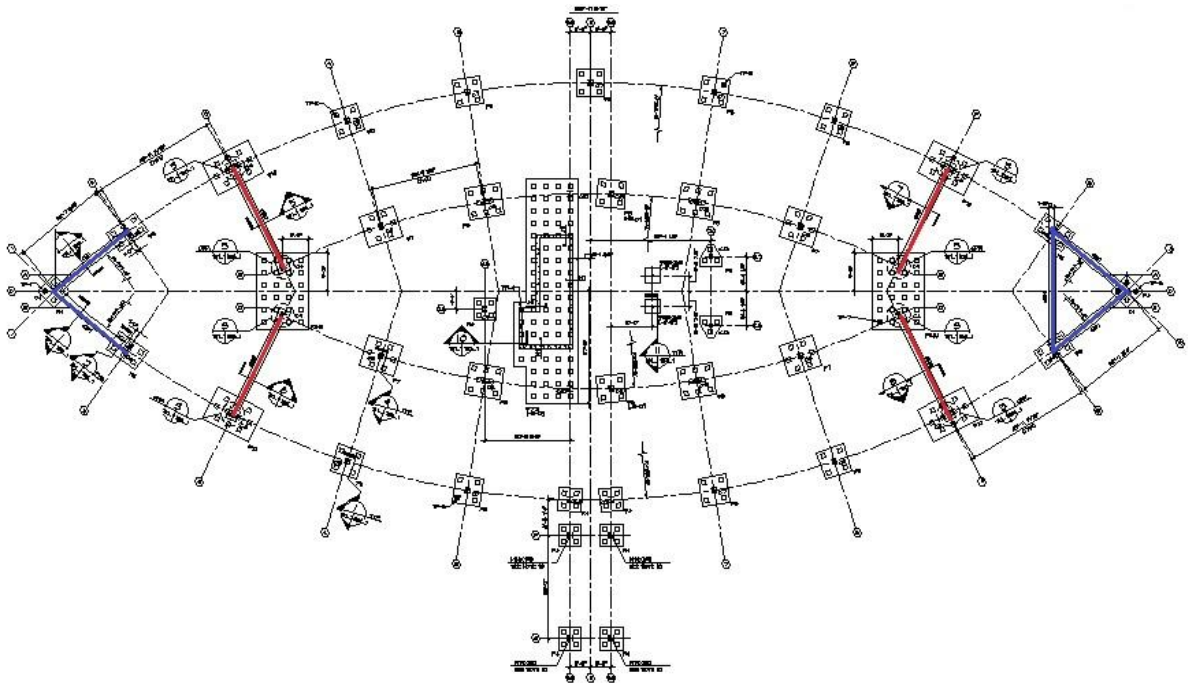

B. Lab Wing

The lab wing foundation consists of concrete pillars attached to concrete footing. The pillars, which are continuous in length, contain #5 rebar at 12" O.C. and are attached to the footing by a lateral pin. *Figure 4* shows the plan view of the concrete pillars.

FIGURE 4

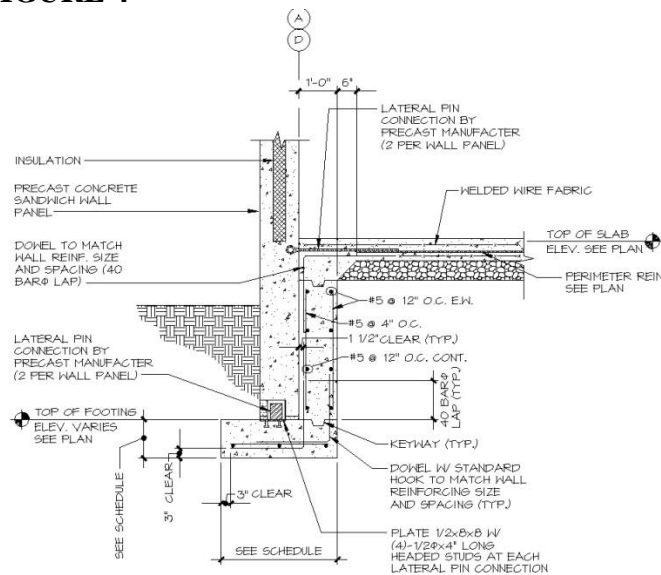

The concrete used in the pillars for the lab wing are 3000psi concrete. They support precast concrete walls. The footings that support these walls are continuous in length. They range from 2'-0" wide by 1'-0" thick to 7'-0" by 1'-0". *Table 2* shows the footing schedule. The "A" bars indicate reinforcing in concrete deposited against the ground. The "B" bars indicate reinforcing in the concrete exposed to earth or weather.

TABLE 2 – Source: Clark Nexsen

FOOTING SCHEDULE						
MARK	DIMENSIONS			REINFORCEMENT		NOTES
	W	L	T	'A' BARS	'B' BARS	
CF2.0	2'-0"	CONT.	1'-0"	(2) #5s CONT.	#5s @ 4'-0" O/C	1
CF3.0	3'-0"	CONT.	1'-0"	(3) #5s CONT.	#5s @ 4'-0" O/C	1
CF4.0	4'-0"	CONT.	1'-0"	(4) #5s CONT.	#5s @ 6' O/C	1 2
CF7.0	7'-0"	CONT.	1'-0"	(6) #5s CONT.	#5s @ 6' O/C	1 2
F4.0x4.0	4'-0"	4'-0"	1'-0"	(6) #4s	(6) #4s	1
F8.5x8.5	8'-6"	8'-6"	1'-8"	(7) #7s	(7) #7s	1

The lab wing also contains a 23" wide by 30" deep grade beam, GB1 along vertical grid line 1.5.

2. Floor System

A. Office Building

The floor system of the office building is consistent from the second floor to the seventh floor. These floors contain 4.5" total thickness composite steel deck and slab. This slab consists of lightweight concrete placed on a 2" deep, .038" thick galvanized steel deck. The steel deck conforms to ASTM A653-94 specifications and has a minimum yield strength of 33ksi. The beams are wide flange steel beams arranged in various grids that form together to fit the curved shape of the building. *Figure 5* shows the floor plan from floor 2 to floor 7.

FIGURE 5 - Source: Clark Nexsen

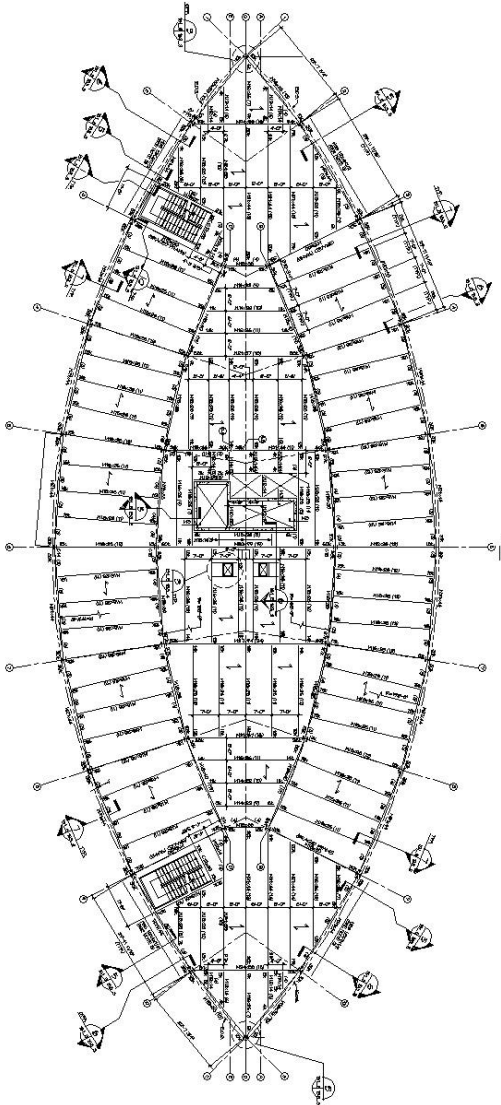

The first floor of the office building contains three separate load-bearing reinforced concrete slabs. The first slab is at the center of the building. It consists of a 5" slab on grade with 6x6-W2.9xW2.9 WWF placed on 6" porous fill.

There is also a triangular slab in the back of the building. This slab is 8" slab on grade with #4 bars at 12" O.C. Finally, there is a slab on the floor of the stairwells. These slabs are a 6" slab on grade with 6x6-W2.9xW2.9 WWF. *Figure 6* shows the first floor plan. The 5" slab is outlined in blue, the 8" inch slab is outlined in red, and 6" slab is outlined in green.

FIGURE 6 – Source: Clark Nexsen

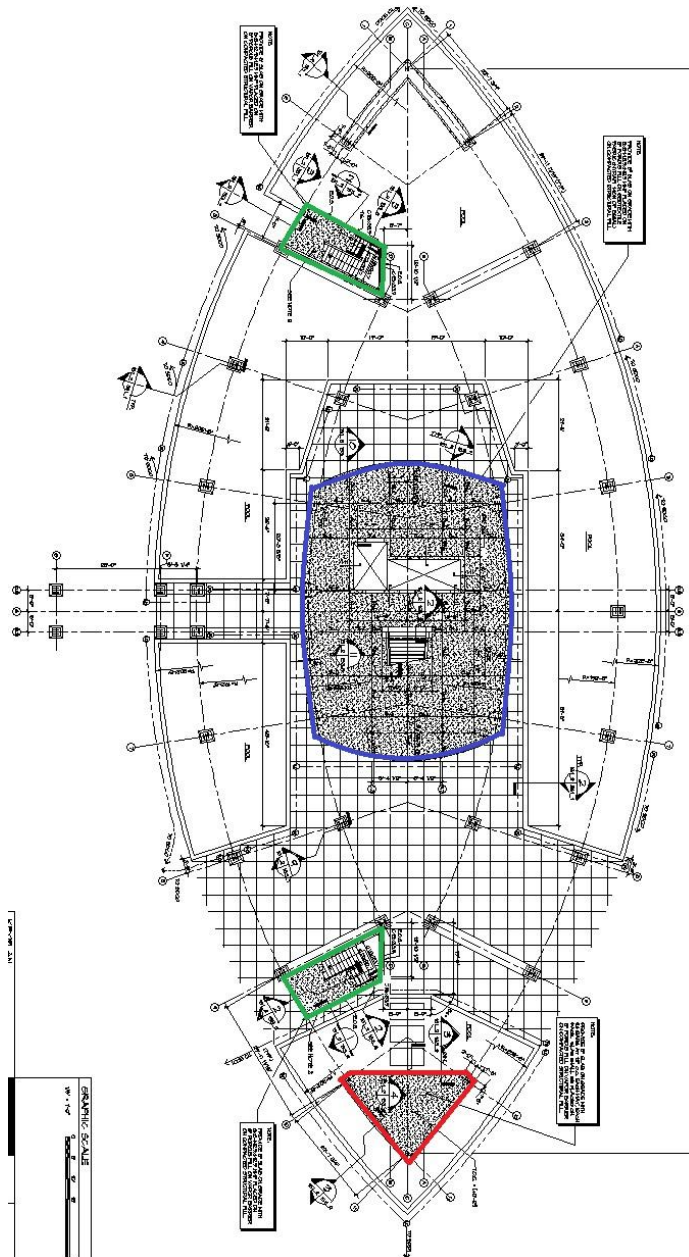

B. Lab Wing

The lab wing consists of a 4" reinforced concrete slab. The slab is reinforced with 6x6 W2.0xW2.0 WWF. This concrete used in the slab is 4000psi.

3. Roof System

A. Office Building

The roof structure of the office building is 1 1/2" corrugated composite steel deck. The deck sits on wide flange steel roof beams. *Figure 7* shows the section view of the roof.

FIGURE 7 – Source: Clark Nexsen

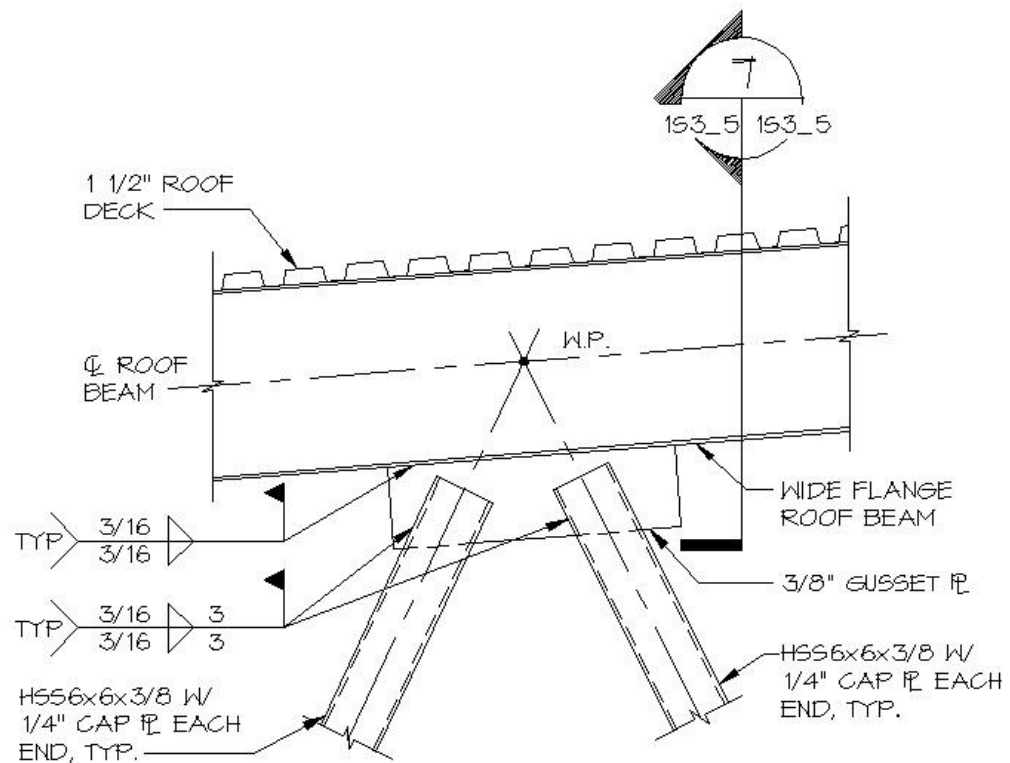

B. Lab Wing

The roof of the lab wing involves gable trusses, spanning between concrete columns. The gable trusses are constructed using WT9x25, L2 1/2x2 1/2x3/16, and W8x28 steel members. On the gable trusses is a 20GA 1 1/2" deep wide rib roof deck. *Figure 8* shows a section view of the gable trusses.

FIGURE 8 – Source: Clark Nexsen

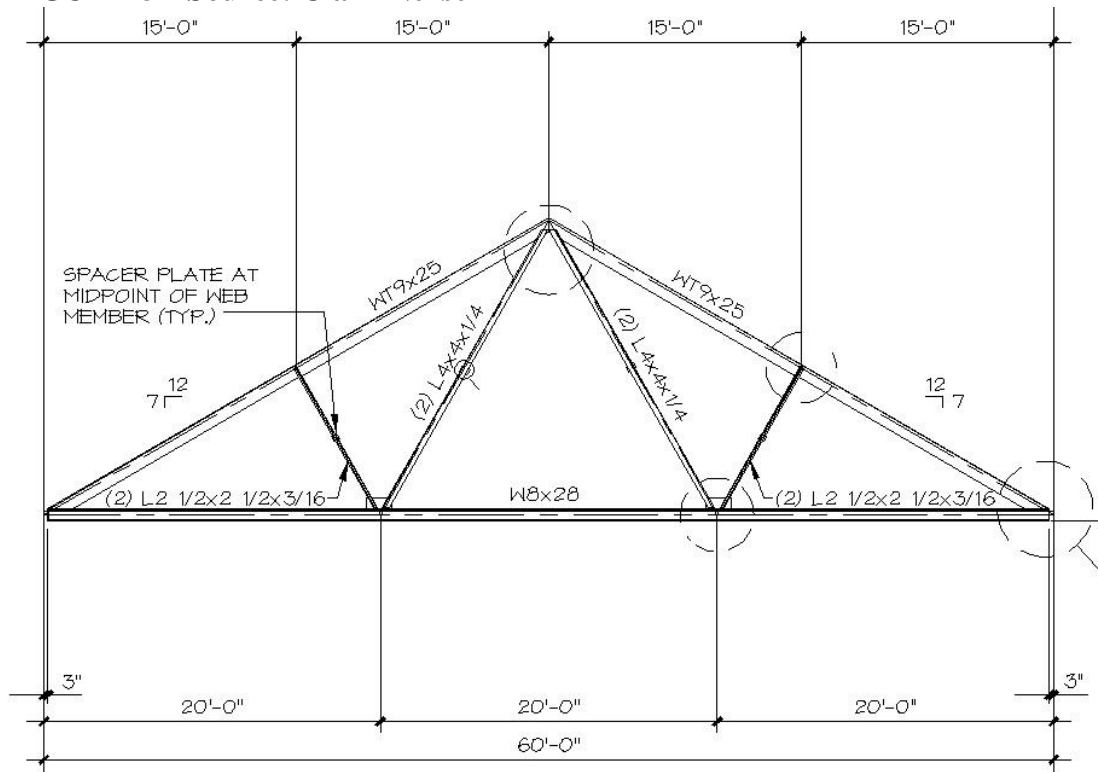

There is also a special truss located along column line 2.5. For these trusses, bottom chord members are W8x31 and the top chord members are WT9x27.5.

4. Columns

A. Office Building

The office building contains steel wide flange columns. 42 columns are arranged to fit the curved shape of the building. The columns used are W8, W10, W12, and W14 steel members. These wide flange columns are encased by concrete piles on the foundation to provide extra structural stability. This is important on the foundation because, as previously stated, the building is raised off the ground to provide protection against flooding. The number of piles used for each column varies from 2 to 9.

These columns on floors 1 to 7 direct gravity loads to the foundation where the columns and concrete piles direct the loads to the earth's foundation.

B. Lab Wing

The lab wing uses concrete columns. These columns vary in size, with the most common size being 24"x24" precast concrete. The columns are accompanied by concrete piles at the foundation in order to provide extra strength at the foundation of the building.

5. Lateral System

A. Office Building

The lateral system of the office building consists of a "K" braced frame. This braced frame occurs at column lines 3 and 9. The frame consists of wide-flange steel members as well as HSS steel members. The wide-flange members are used as columns. The HSS members are used as diagonal bracing. The wide-flange members are W14 and range from W14x82 at the top, W14x90 in the middle, and W14x159 at the bottom. The HSS members range from HSS 8x8 at the top to HSS 10x10 in the middle, and finally HSS 12x12 at the bottom.

"X" bracing is used in three bays of this structure: the outer bays on the bottom level as well as the middle bay in the penthouse level. "X" bracing is used on these floor as added bracing because of the loads on the floors. As discussed later in the "Wind Load" section, the penthouse sees the highest load in psf from wind. The penthouse also lacks the outer bays to help deflect the load like the floors below it have. The bays on the bottom level have the added weight of the floors above to take into consideration. The "X" bracing allows one diagonal brace to be in tension and one to be in compression. *Figure 9* shows the location of the "K" braced frame and *Figure 10* shows the "K" braced frame in section.

FIGURE 9 – Source: Clark Nexsen

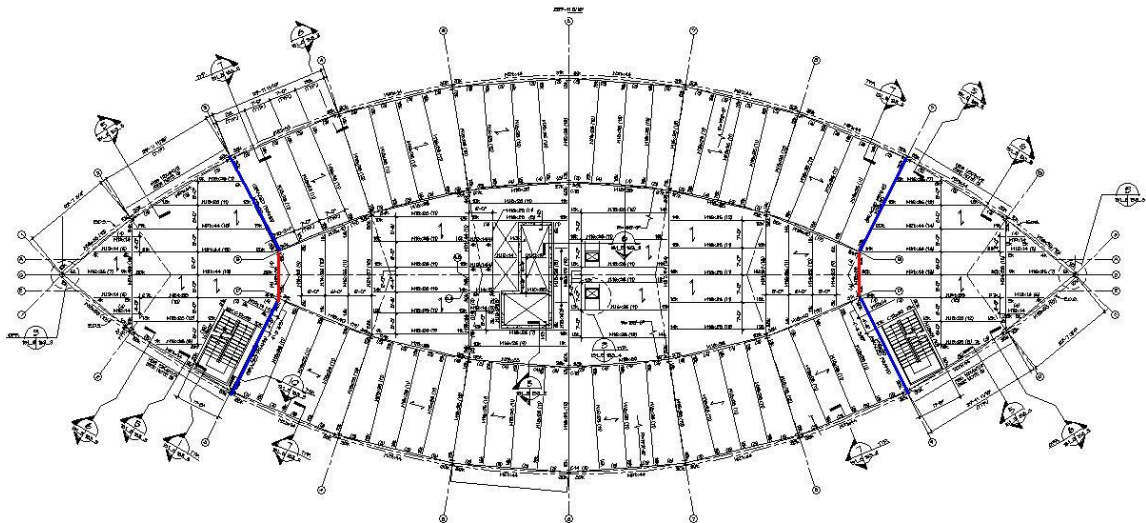

The unique design of the building caters to the shape of the frame. The outer bays are perpendicular to the load and transfer the load to the middle bays as well as down through the cross bracing. *Figure 11* shows the load path of the frame.

FIGURE 11 – Source: Clark Nexsen

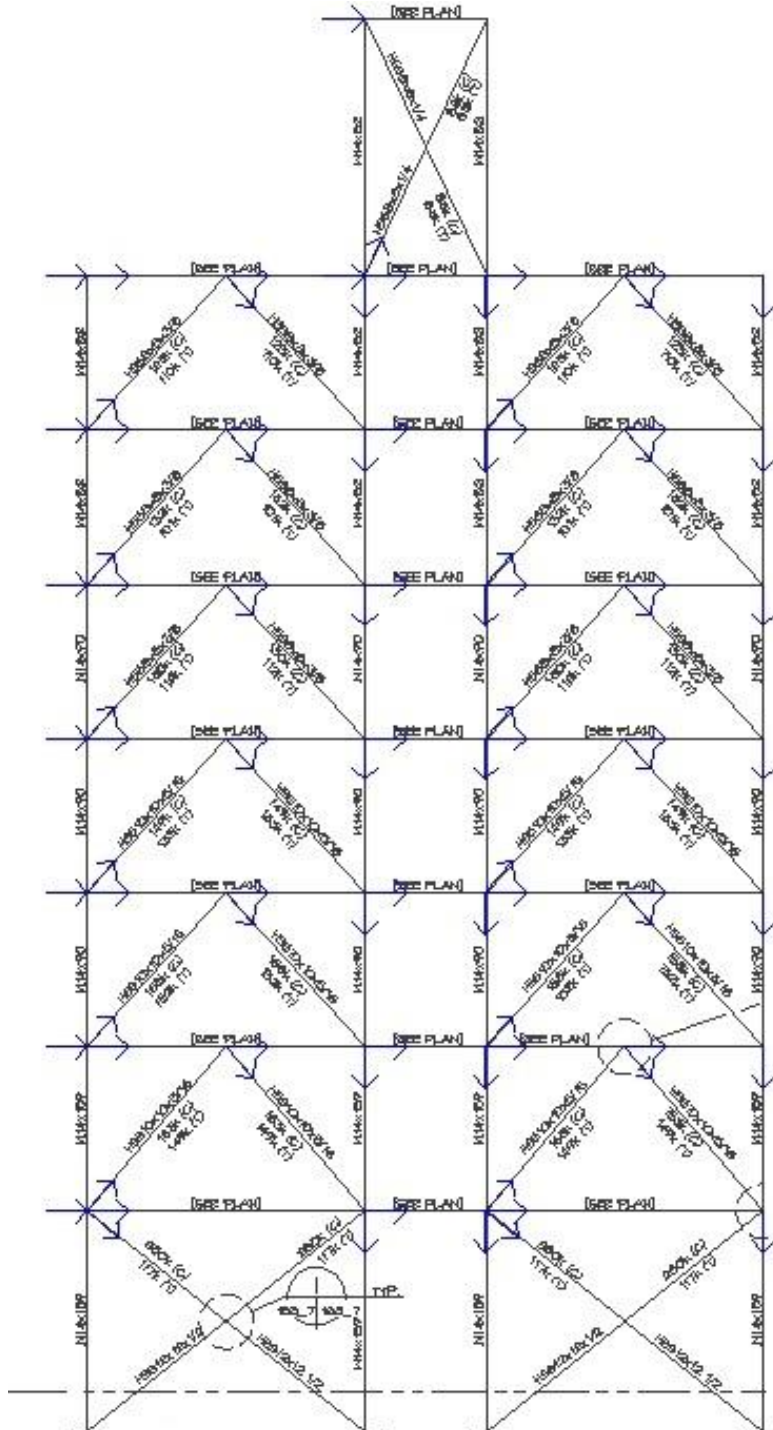

B. Lab Wing

The lateral support for the lab wing is provided by sheer walls. 8" precast lightweight concrete walls are used as sheer walls throughout the lab wing of the building. These walls combine with the concrete slabs to provide lateral support for the building.

6. Structural Details

A. Sandwich Wall

The lab wing makes use of concrete sandwich walls. Sandwich walls are resistant to many important forces of nature including, earthquakes, hurricanes, heat, cold, and flooding. Flooding is the most important natural force in the situation of the Virginia Advanced Shipbuilding & Carrier Integration Center. As stated earlier, the office building uses stilts with thick concrete piles to avoid problems caused by the flooding of the James River. The lab wall instead makes use of the sandwich wall in order to defend against flooding. *Figure 10* shows the sandwich wall in section.

FIGURE 12 – Source: <http://www.cswall.com/CSW/Walls/index.htm>

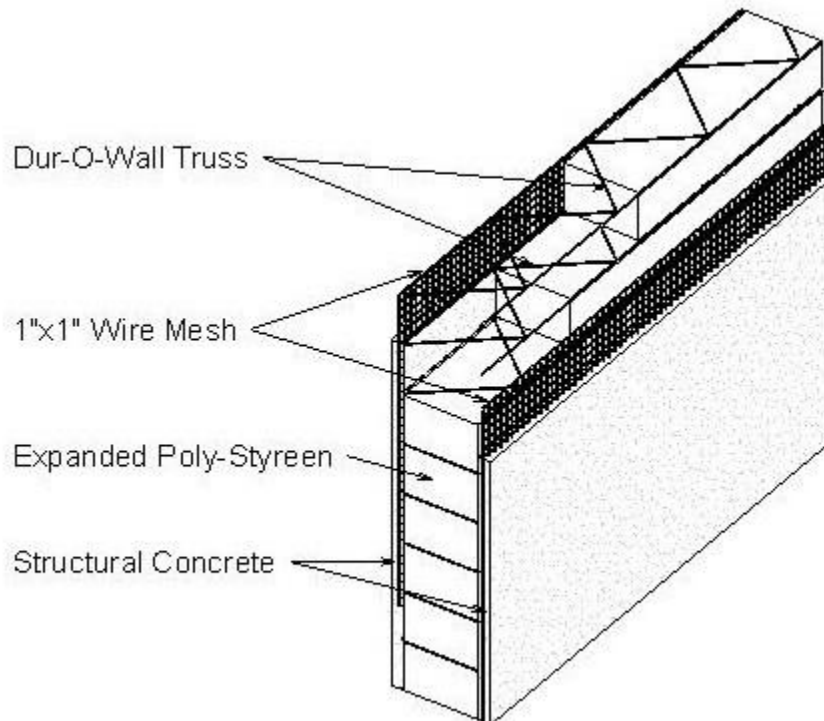

B. Column Splice Connections

The height of the office building makes it necessary for column splice connections to be used. *Figure 11* shows the typical column splice details.

FIGURE 13 – Source: Clark Nexsen

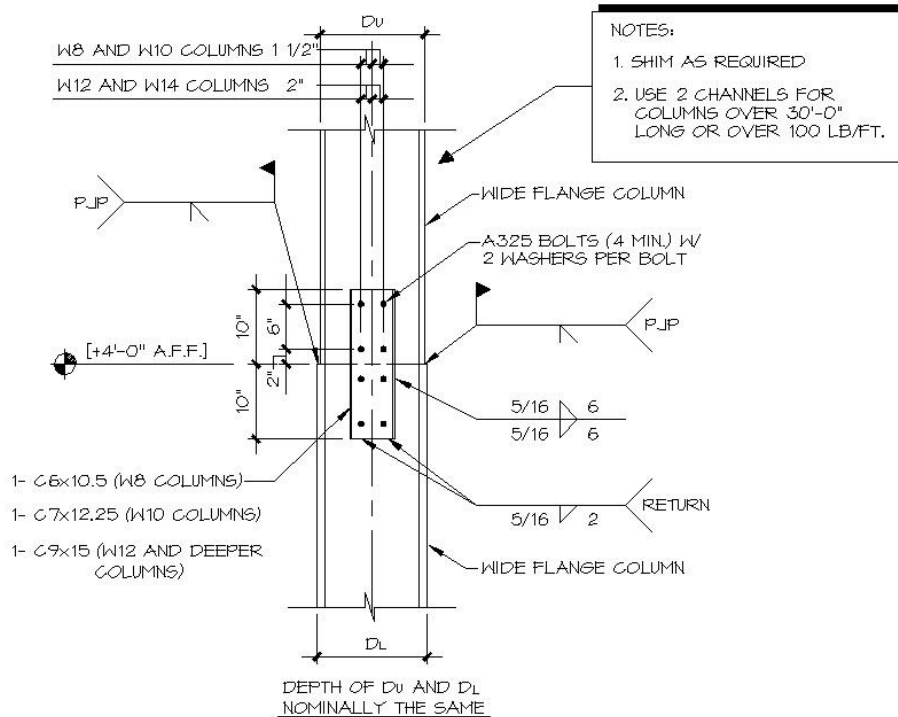

It is important to note the variance of the connections from the W8 to the W14 columns. A325 bolts are used. Also, 2 channels are used for columns over 30'-0" long or over 100lb/ft.

7. Conclusions on Structural System

The first thing that was noticed when looking at the structural drawings is the vast difference between the office building and the lab wing. The office building makes use of steel columns and beams as well as diagonal steel bracing. The lab wing, however, makes use of concrete slabs and concrete columns as well as shear walls and sandwich walls.

Flooding is an important natural force that had to be accounted for in the structural design of the building. The building had to be designed to withstand flood loads. The use of large concrete areas on the ground floor are designed to resist these loads. The ground floor does not contain offices or any rooms. Instead, the offices are located above flood levels in the floors above the ground floor. This allowed the ground floor to keep an open feel to it even with the large areas of concrete. The office building makes use of stilts and thick concrete piles to remain above flood level. The Lab wing, however, makes use of sandwich walls.

The use of steel in the office building is most likely due to the architect wanting to keep the office building more open and spacious and not have to worry about large, cramping concrete columns. The steel columns and beams are complimented by the curtain wall that engulfs the building. This provides a light, spacious, and well-lit office building.

The lab wing, on the other hand, is designed as a seemingly heavier, less spacious building. Most business will be taking place in the office building and it is clear that the designer wanted the office building to feel more welcoming. The parking deck makes use of concrete because it is most likely cheaper to design a parking deck out of concrete. Also, while the laboratories will be operated during the day, they make more use of artificial lighting and rely less on natural light.

Problem Statement

As discussed throughout the first three technical reports, the architecture and shape of the building are extremely important to the Virginia Advanced Shipbuilding & Carrier Integration Center. The building's unique shape, however, leads to confusing column layouts, which in turn leads to even more confusing beam and joist layouts. Some beams seemed to span great distances while other beams spanned only a few feet. This creates a great difference in floor depth throughout the bays as many different sizes of wide flange members are used. One way to fix this problem is to use reinforced concrete columns and slabs as opposed to steel members.

Unfortunately, if a concrete slab is designed for gravity loads, a new lateral resisting system will need to be designed. The existing K-braced frame is not compatible with a concrete floor system as it makes use of steel wide flange and hollow steel section members. Lateral resistance can be accomplished with the use of concrete shear walls.

Problem Solution

In order to solve this problem, a new column layout will be investigated. This new column layout will allow for a uniform slab thickness throughout the building. A uniform slab thickness will cut down on construction cost. More importantly, the new column layout will achieve a lower floor thickness. As stated in Technical Report II, the reason concrete was not used for the VASCIC was due to the fact that the office building looked to achieve a light, open feel. The concrete may take away from this idea slightly, however the reduced floor thickness may actually contribute to the look.

Shear walls will have to be designed in order to create a lateral resistance system that is compatible with the new concrete slab. The symmetrical shape of the building will make this redesign simpler. It will not be difficult to place shear walls strategically throughout the building in order to achieve minimal to no torsional effect.

In order to compare the new structural system with the existing system, an ETABS model be created for both the gravity and lateral loads.

Breadth Study I

The complete redesign of the structural system will create differences in the cost of the building as well as the construction schedule. The first breadth study will look into the impact a complete redesign will have of the cost of the building. The construction schedule will also be taken into account. Included in this study will be comparisons between the cost of the steel used in the existing structure and the cost of the concrete used in the redesign. Construction costs will also be compared. Finally, the impact on the schedule (whether the concrete structure would take longer to build or shorter to build) will be analyzed.

Breadth Study II

The redesign of the structural system will also include a redesign of the column layout. Breadth two will include an investigation into multiple column layouts in order to find the layout most suitable for the building. The open and light aspects of the architecture must be taken into account. In order to accomplish this with the new concrete design, low floor thicknesses as well as small, well-spaced columns must be designed.

The lateral system must also be redesigned, as the existing steel frame will not coincide with the new concrete structure. The existing lateral frame had perfect symmetry about the building and created no torsional effect. This breadth study will include redesigns of the lateral structure via shear walls in an attempt to keep the eccentricity close to or, optimally, zero.

Proposed Solution & Methods

The redesign will be performed using the ACI 318-08, ACE 7-05 manuals. ETABS will also be used in order to compare a computer solution with hand solutions. The floor system as well as the shear walls will be designed using ACI 318-08. ACE will then be used to determine the new wind and seismic forces dependent upon the new floor-to-floor heights. The design will then be analyzed, using the new wind and seismic pressures, in ETABS. Because of the new column layout, multiple design ideas will be analyzed in order to find the most suitable design. Designs that result in a building that does not meet ASCE 7-05 requirements will be scrapped. The most suitable design will be determined based on how drastically the design impacts the architecture, cost, and construction schedule of the building.

Tasks

The following tasks will be completed for multiple designs. The resulting designs will be compared and the most suitable design will be chosen for the final redesign.

1. Redesign column layout
2. Two-way flat slab design
 - a. Design per ACI 318-08
3. Column design
 - a. Design concrete columns per ACI 318-08
 - b. Look to minimize column size
4. Redesign lateral system
 - a. Design concrete shear walls per ACI 318-08
 - b. Re-calculate wind and seismic load
 - c. Analyze lateral system using ETABS
5. Compare results
 - a. Investigate cost of each system
 - b. Investigate time needed to construct each system
 - c. Investigate the impact each system has on the architecture of the building
6. Chose most suitable design
7. Prepare for presentation

Schedule

1/9-1/15	1/16-1/22	1/23-1/29	1/30-2/5	2/6-2/12	2/13-2/19	2/20-2/26	2/27-3/5	3/6-3/12	3/13-3/19	3/20-3/26	3/27-4/1	4/2-4/7
Redesign Column Layout	Concrete Slab Design	Column Design	Redesign Lateral System	Compare results	Chose most suitable design	Prepare for presentation						